

# Chancellor Heavy Duty Top Roller Screen

When a large commercial screen is required for multi purpose environments and the screens must retract out of the way, the Chancellor is the professional choice for motorised screens.

## APPLICATIONS

4000mm to 6500mm in width

Multi purpose rooms

Conference Rooms

Educational Facilities

## PRODUCT FEATURES

Chancellor for screens 4m to 6.5m in width

Top roller design

Steel box frame construction/clad in timber

Motor C  approved

Custom sizes and formats available

Fire rate surface

Quality Assurance AS/NZS ISO 9001:2000

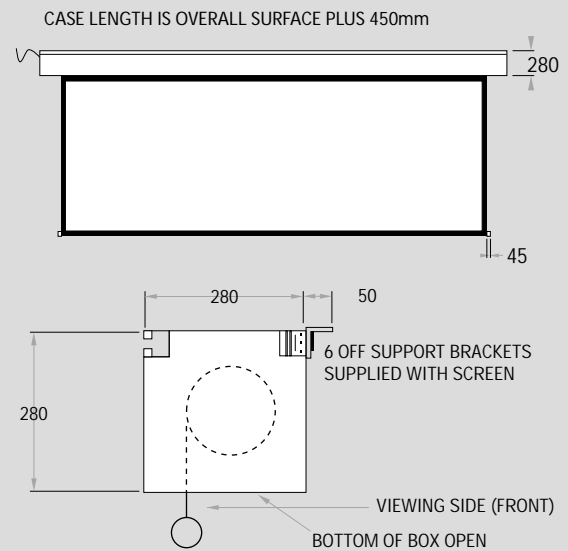

## CHANCELLOR

Item No.	Picture (mm)	Format
0850009	5000 x 5000	Square
0855009	5500 x 5500	Square
0860009	6000 x 6000	Square
0865009	6500 x 6500	Square
0822519	3430 x 4570	4:3
0825019	3810 x 5080	4:3
0827519	4190 x 5590	4:3
0830019	4570 x 6100	4:3



[www.screentechnics.com.au](http://www.screentechnics.com.au)

# Admiral Heavy Duty Bottom Roller Screen

For projects that require a motorised screen at 6500mm wide or over, the bottom roller design gives the best possible lay flat for these challenging installations.

## APPLICATIONS

6500mm to 15000mm in width

Multi purpose rooms

Conference Rooms

Educational Facilities

## PRODUCT FEATURES

Admiral for screens 6.5m to 15m in width

Bottom roller design

Steel box frame construction

Motor C  approved 240 volt

Custom sizes and formats available

Fire rated surface

Quality Assurance AS/NZS ISO 9001:2000

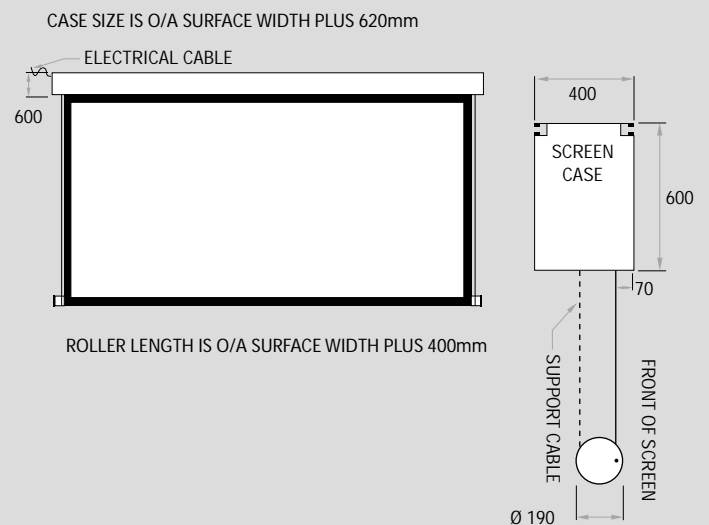

### ADMIRAL

Item No.	Picture (mm)	Format
0970009	7000 x 7000	Square
0980009	8000 x 8000	Square
0935019	5330 x 7110	4:3
0940019	6100 x 8130	4:3
0945019	6860 x 9150	4:3
0950019	7620 x 10160	4:3
0955019	8380 x 11180	4:3



[www.screentechnics.com.au](http://www.screentechnics.com.au)